

# 150 kW Triton Diesel Generator – EPA Certified TP-P150-T3



Triton Generators are designed and engineered to power a variety of projects and can be completely customized for your exact requirements.



## FEATURES

- ✓ Fully Integrated Power Generation System
- ✓ Prototype-tested, Factory Built and Fully Tested
- ✓ Open-Source Components and Controls
- ✓ Designed to Power any application

## OPTIONS:

- ✓ Sound Attenuated Enclosure
- ✓ Paralleling Controls
- ✓ UL2200 and CSA Available
- ✓ Extended Warranty
- ✓ Trailer with Extended Fuel Capacity
- ✓ Over 100 Additional options



## OUTPUT RATINGS

Available Voltages at 60Hz	Standby		Prime	
	kW	kVA	kW	kVA
Single Phase, 1.0 Power Factor 110/220, 120/240	-	-	-	-
Three Phase, 0.8 Power Factor 120/208, 277/480	153	191	136	170
*Other Voltages Available				

## OUR ENGINES

The Perkins 1106D-E70TAG3 is a six-cylinder, turbocharged and air-to-air aftercooled diesel engine engineered for high-output performance and Tier 3 emissions compliance in modern power generation applications. Operating at 1800 rpm, it delivers 178 kWm (239 hp), offering excellent fuel efficiency, strong power density, and long-term durability. At Triton Power, we rely on engines like the Perkins 1106D-E70TAG3 because they provide consistent power delivery, reduced environmental impact, and dependable global parts and service support—making them a trusted solution for demanding commercial and industrial generator sets.

## OUR ALTERNATORS

Triton Generators are equipped with Stamford and Leroy-Somer alternators. Utilizing the latest technologies and with outputs extending from 5 to 5,000 kW, these alternators are designed to deliver superior efficiencies in Standby, Continuous and Prime generator applications worldwide.

Manufacturer reserves the right to make changes in model, technical specifications, color, equipment and accessories without prior notice. All photos are representative and may not reflect exact model

## ENGINE INFORMATION

<i>Engine Make</i>	Perkins
<i>Model</i>	1106D-E70TAG3
<i>Tier Rating</i>	Tier 3
<i>Engine Speed (RPM)</i>	1800
<i>Engine Power Output at rated RPM</i>	178 kWm / 239 HP
<i>Cooling</i>	Radiator Cooled
<i>Aspiration</i>	Turbocharged Aftercooled
<i>Total Displacement (Liter)</i>	7.01
<i>No. of Cylinders and Build</i>	6, in line
<i>Bore and Stroke</i>	105 x 135
<i>Compression Ratio</i>	16.8:1
<i>Governor</i>	Electronic
<i>Fuel Consumption (L/hr)</i>	
<i>Full Load</i>	42.3
<i>75% Load</i>	34.7
<i>50% Load</i>	23.8
<i>Oil Capacity (Liter)</i>	16.5
<i>Coolant Capacity (Liter)</i>	21

## ALTERNATOR INFORMATION

<i>Manufacturer</i>	Leroy Somer
<i>Design</i>	Brushless single bearing, revolving field
<i>Stator</i>	2/3 pitch
<i>Rotor</i>	Single bearing, flexible disc
<i>Insulation System</i>	Class H
<i>Standard Temperature Rise</i>	125 -163°C Continuous
<i>Exciter Type</i>	Self-Excited
<i>Phase Rotation</i>	A (U), B (V), C (W)
<i>Alternator Cooling</i>	Direct drive centrifugal blower fan
<i>AC Waveform Total Harmonic Distortion</i>	No load < 1.5%. Non distorting balanced linear load < 5%
<i>Telephone Influence Factor (TIF)</i>	<50 per NEMA MG1-22.43
<i>Telephone Harmonic Factor (THF)</i>	<2%

## DEEP SEA DIGITAL CONTROLLER

- Adaptable for a wide variety of single gen-set applications, supporting diesel, gas and petrol engines.
- Monitors engine speed, oil pressure, coolant temperature, frequency, voltage, current, power and fuel level, giving you comprehensive engine and alternator protection.
- Easy USB configuration via the DSE PC Suite or directly through the controller's panel.
- Standard units include models DSE4520 or DSE4510. Additional models for AutoStart (DSE73XX and DSE74XX Series) and Synchronization (DSE86XX Series) available upon request on customized equipment.





## STANDARD ITEMS

- ✓ Engine System:
  - Air Cleaner
  - Commercial Grade Exhaust (Enclosed Versions)
  - Expanded Metal Safety Guards
- ✓ Fuel System
  - Primary Fuel Filter
  - Flexible Fuel Lines
- ✓ Cooling System
  - Factory Installed Radiator
  - Radiator Drain Extension
- ✓ Electrical System
  - Unit Mounted Mainline Circuit Breaker
  - Battery Charging Alternator
  - Battery Tray and Cables
- ✓ Generator Set
  - Mounted on Heavy Duty Steel Base Frame
  - Anti-Vibration Pads between Engine/Alternator and Frame
  - Full Factory Load Bank Testing
- ✓ Alternator
  - Single or Three Phase Available
  - Class H Insulation
- ✓ Enclosure (if selected)
  - Heavy Duty Steel Enclosure (Aluminum Options)
  - Powder Coated Finish
  - Easy Access to All Service Points
  - Fully Sound Attenuated
  - Easy to Transport

## OPTIONAL ITEMS

- ✓ Engine System:
  - Upgraded Exhaust Silencers (Hospital, Residential, Critical)
  - Heavy Duty Air filters
  - Oil Drain Extension
  - Oil Heater
  - Block Heater (Standard and Circulating)
- ✓ Fuel System
  - Multi-Valve Fuel Connections
  - Fuel Heater
- ✓ Electrical System
  - Battery Charger (Standard, Float Type and Solar)
  - Additional Circuit Breakers
  - Shunt Trips
  - Electrically Controlled Breakers
  - Remote Emergency Stop Switch
  - Remote Monitoring
  - Paralleling Systems
  - Electrical Connections (Cam-Locks, Reefer Plugs, Distro Panel, and more)
  - Multi Voltage Selector Switches
- ✓ Cooling System
  - Upgraded Radiator Systems
  - Marine Grade Coating
- ✓ Enclosure
  - Aluminum Enclosure
  - Ultra-Quiet Enclosure
  - 20 and 40' Container Packages
  - Custom Paint Colors
  - Rodent Guards
- ✓ Alternator
  - 600 Voltage
  - Medium Voltage
  - Two Bearing
  - Tropicalization
  - Anticondensation Heaters
  - PMG
- ✓ Additional Options
  - Fire Suppression Systems
  - Seismic Isolators
  - Remote Control Systems
  - Enclosure Lights
  - Cold and Extreme Weather Packages
  - NFPA 110 Compliance
  - Standard and Custom Fuel Tanks
  - Standard and Custom Trailers
  - Please inquire, Triton can assist in engineering nearly any option

## WEIGHT AND DIMENSIONS

### Skid Mounted

Length (mm)	Inquire
Width (mm)	Inquire
Height (mm)	Inquire
Dry Weight (kg)	Inquire
Fuel Tank (L)	Inquire

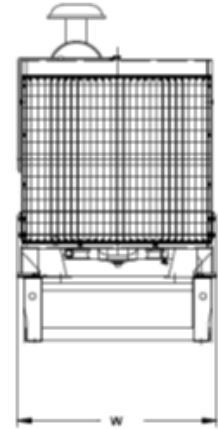
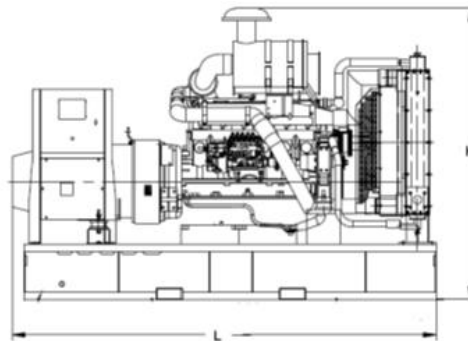

### Enclosed

Length (mm)	3518
Width (mm)	1242
Height (mm)	1842
Dry Weight (kg)	2670
Fuel Tank (L)	300

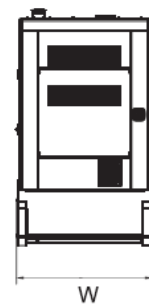
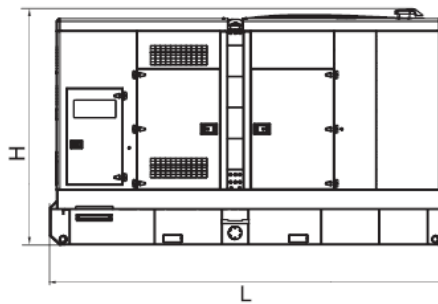

\*Drawings are representative only and do not reflect actual product

## ENCLOSURE FEATURES AND BENEFITS

- ✓ Made of high-quality steel and completely powder coated. The paint has a three-step process ensuring protection.
- ✓ Advanced water and dust proof design of service doors and enclosure.
- ✓ Noise reduction enhanced by an exhaust silencer and high quality interior acoustic lining that is sound absorbent and fire-retardant
- ✓ Built for easy installation, maintenance and transport
- ✓ Lifting eyes located at base make it easier to move and transport.
- ✓ Easy to Maintain with Access on both sides, includes Integral base drainage outlets, modular enclosure for easy parts replacement.

TRITON POWER CORP  
 8511 NW 61 STREET MIAMI, FL USA  
 305-592-6300 Fax: 305-592-5900  
 email: [info@tritonpower.com](mailto:info@tritonpower.com)  
 website: [tritonpower.com](http://tritonpower.com)