

CATERPILLAR®

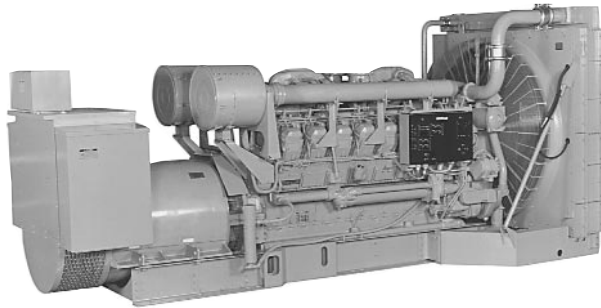

FEATURES

■ FULL RANGE OF ATTACHMENTS

- Wide range of bolt-on system expansion attachments, factory designed and tested

■ SINGLE-SOURCE SUPPLIER

- Complete systems designed and built at Caterpillar ISO certified facilities
- **Certified Prototype Tested** with torsional analysis

■ WORLDWIDE PRODUCT SUPPORT

- Worldwide parts availability through the Caterpillar dealer network
- With over 1,200 dealer outlets operating in 166 countries, you're never far from the Caterpillar part you need.
- 99.5% of parts orders filled within 48 hours; best product support record in the industry.
- Caterpillar dealer service technicians are trained to service every aspect of your electric power generation system.
- Preventive maintenance agreements
- The Cat Scheduled Oil Sampling (S•O•SSM) program cost effectively detects internal engine component condition, even the presence of unwanted fluids and combustion by-products

■ MEETS OR EXCEEDS INTERNATIONAL SPECIFICATIONS: ABGSM TM3, AS1359, AS2789, BS4999, BS5000, BS5514, DIN6271, DIN6280, EGSA101P, IEC 34/1, ISO3046/1, ISO8528, JEM1359, NEMA MG1, VDE0530, 89/392/EEC, 89/336/EEC

■ CAT® 3516B DIESEL ENGINE

- Reliable, rugged, durable design
- Field-proven in thousands of applications worldwide
- Four-stroke-cycle diesel engine combines consistent performance and excellent fuel economy with minimum weight
- Advanced electronic engine controls allow the customer to choose either Lo BSFC or low emissions engine configurations

Generator Set

2000 kW

1800 rpm

60 Hz

Standby Power

Caterpillar is leading the power generation marketplace with Package Generator Sets engineered to deliver unmatched flexibility, expandability, reliability, and cost-effectiveness.



■ CAT® SR4B GENERATOR

- Designed to match performance and output characteristics of Caterpillar diesel engines
- Optimum winding pitch for minimum total harmonic distortion and maximum efficiency
- Segregated AC/DC, low voltage accessory box provides single point access to accessory connections

■ CATERPILLAR® EMCP II Electronic Modular Control Panel

The Electronic Modular Control Panel (EMCP II) is a generator-mounted control panel, available on all Caterpillar packaged generator sets. It utilizes environmentally sealed, solid-state, microprocessor-based modules for engine control and AC metering.

The EMCP II provides these standard control and monitoring features:

- Automatic/manual start-stop engine control with programmable safety shutdowns and associated flashing LED indicators for low oil pressure, high coolant temperature, overspeed, overcrank, and emergency stop
- Cycle cranking — adjustable 1-60 second crank/rest periods
- Cooldown timer — adjustable 0-30 minutes
- Energized to run or shutdown fuel control systems
- LCD digital readout for: engine oil pressure, coolant temperature, engine rpm, system DC volts, engine running hours, system diagnostic codes, generator AC volts, generator AC amps, and generator frequency
- Engine control switch
- Ammeter-voltmeter phase selector switch
- Emergency stop pushbutton
- Indicator/display test switch
- Voltage adjust potentiometer
- Rugged NEMA 1/IP 23 cabinet

FACTORY INSTALLED STANDARD & OPTIONAL EQUIPMENT

SYSTEM	STANDARD	OPTIONAL
Air inlet	regular-duty air cleaner service indicator	dual element air cleaner air inlet shutoff
Cooling	radiator, fan, drives, and guard aftercooler high coolant temperature alarm and shutdown	Caterpillar Extended Life Coolant optional radiators duct flanges coolant level sensor heat exchanger and expansion tank dual jacket water heaters low coolant level shutdown
Exhaust	ANSI weld flange dry exhaust manifold	muffler exhaust flange and expanders pyrometer and thermocouples
Fuel	fuel cooler on emissions package fuel filter fuel transfer pump	fuel cooler on Lo BSFC packages water separator fuel priming pump primary fuel filter low fuel level alarm and shutdown
Generator	self excited anti-condensation space heaters Voltage Regulator VR3 — low voltage	oversized and premium generators digital voltage regulator digital voltage regulator with kVAR/PF control circuit breakers bearing temperature RTDs PM conversion stator temperature detector RTDs PM excited high voltage generators voltage regulator KCR760 — high voltage inlet air filters RFI filters
Governor	Caterpillar® ADEM control system	load share module
Control panels	EMCP II	EMCP II+ switchgear conversion
Lube	crankcase breather (2-in. OD outlet) oil filter, cooler, filler, and dipstick low oil pressure alarm and shutdown	fumes disposal electric prelube sump pump
Mounting	13-in. structural steel rails	vibration isolators
Starting/ charging	24 volt electric starting motor	10 amp battery charger 35 amp charging alternator 60 amp charging alternator air starters ether starting aid battery rack and cables
Other		enclosure Customer Communication Module crankcase explosion relief valves power takeoff CE certification engine barring group

2000 kW GENERATOR SET



TECHNICAL DATA

2000 ekW/2500 kV•A Standby Power Generator Set — 1800 rpm/60 Hz					
Package Performance Power Rating @ 0.8 PF with Fan	ekW	2000			
Engine rating without Fan	kV•A	2500			
Engine Lubricating Oil Capacity — Requires CF-4 Oil	bhp	2876			
Engine Coolant Capacity without Radiator	gal	110.0			
Exhaust Flange Size — (Internal Diameter)	gal	61.6			
Exhaust System Backpressure (Max Allowable)	in	12			
	in H ₂ O	27			
Low Emissions Version — SCAC					Lo BSFC— JWAC
DM Number		DM1062-11	DM1394-10	DM1395-11	DM2063-10
Coolant to Aftercooler Temperature (Max)	Deg F	86	140	194	194
Fuel Consumption and Emissions					
100% load with Fan	lb/bhp-hr	.357	.357	.349	.339
per ISO3046/1: +1-3% tolerance	gph	145.3	145.4	142	137.5
NO _x emissions at ISO standard conditions; ±15% tolerance	g/hr	12 718	15 557	19 824	25 328
	lb/hr	28.04	34.30	43.71	55.85
75% load with Fan	lb/bhp-hr	.349	.349	.346	.333
per ISO3046/1: +1-3% tolerance	gph	107.0	107.0	106.2	101.5
NO _x emissions at ISO standard conditions; ±15% tolerance	g/hr	9536	11 670	14 891	20 178
	lb/hr	21.03	25.73	32.83	44.49
75% load with Fan	lb/bhp-hr	.352	.353	.352	.335
per ISO3046/1: +1-3% tolerance	gph	73.1	73.4	73.0	69.2
NO _x emissions at ISO standard conditions; ±15% tolerance	g/hr	6446	7879	10 136	14 456
	lb/hr	14.21	17.37	22.35	31.88
Cooling System					
Air Flow Restriction (after radiator)	in H ₂ O	.5	.5	.5	.5
Engine Coolant Capacity with Radiator	gal	105.6	105.6	105.6	119.6
Aftercooler Capacity	gal	7.4	7.4	7.4	7.4
Aftercooler Pump Flow @ 9.5 ft H ₂ O head	gal/min	150	150	150	150
Exhaust System					
Combustion Air Inlet Flow Rate	ft ³ /min	6317	6172	5904	5752
Exhaust Gas Stack Temperature	Deg F	928	963	970	946
Exhaust Gas Flow Rate	ft ³ /min	16 963	17 051	16 433	15 745
Heat Rejection					
Heat Rejection to Jacket Water Coolant	Btu/min	43 790	45 610	46 975	68 869
Heat Rejection to Aftercooler	Btu/min	35 544	30 823	25 080	22 862
Heat Rejection to Exhaust	Btu/min	123 465	126 024	122 441	116 015
Heat Rejection to Atmosphere from Engine	Btu/min	8587	9042	9440	8929
Heat Rejection to Atmosphere from Generator	Btu/min	4720	4720	4720	4720

*Note: For permitting see TMI data.

CAT® 825 FRAME GENERATOR SPECIFICATIONS

Type	Self excited, static regulated, brushless
Construction	Single bearing, close coupled
Three phase	Wye connection, 6 lead
Insulation	Class H with tropicalization and antiabrasion
Enclosure	Drip proof IP22
Alignment	Pilot shaft
Overspeed capability	150%
Wave form	Less than 5% deviation
Paralleling capability	Standard
Voltage regulator	3-phase sensing with VR3
Voltage regulation	Less than ±1/2% (steady state) Less than ± 1% (no load to full load)
Voltage gain	Adjustable to compensate for line loss
TIF	Less than 50
THD	Less than 5%

CAT® 3516B ENGINE SPECIFICATIONS

V-16, 4-Stroke-Cycle Watercooled Diesel	
Bore — in (mm)	6.7 (170)
Stroke — in (mm)	7.5 (190)
Displacement — cu in (L)	4210 (69)
Compression ratio	14.0:1
Aspiration	Turbocharged-Aftercooled
Fuel System	Direct Unit Injection

CAT® CONTROL PANEL

24 Volt DC Control
NEMA 1, IP23 enclosure
Electrically dead front
Lockable hinged door
Generator instruments meet ANSI C-39-1
Terminal box mounted
Single location customer connector point
EC compliant — segregated AC/DC connection

Consult your Caterpillar dealer for available voltages.

STANDBY POWER GENERATOR SET PACKAGE — TOP VIEW

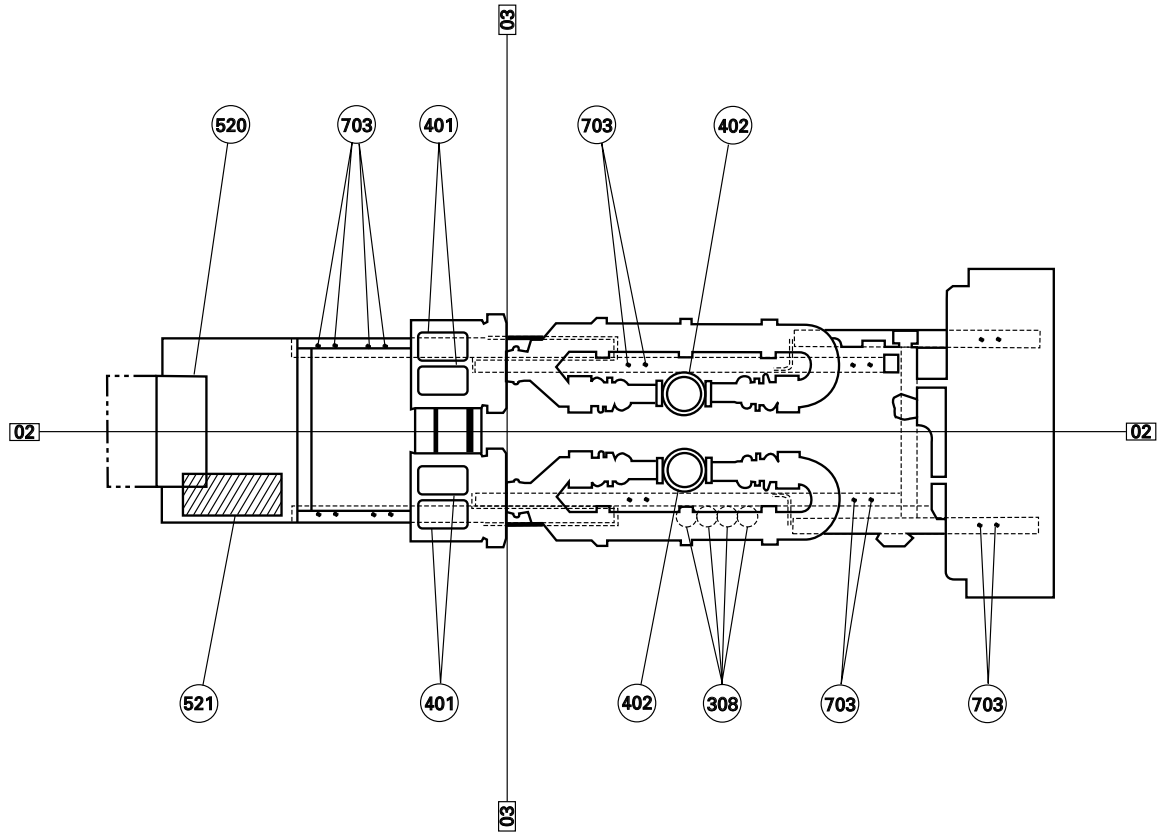

- 02 Centerline of Engine
- 308 Oil Filter
- 402 Exhaust
- 521 Conduit Entrance
- 03 Rear Face of Cylinder Block
- 401 Air Inlet
- 520 Control and Power Panel
- 703 Customer Mounting Holes

PACKAGE DIMENSIONS			
		Low Emissions	Lo BSFC
Length	in (mm)	225.89 (5737.7)	226.65 (5756.9)
Width	in (mm)	82.01 (2083.0)	91.59 (2326.4)
Height	in (mm)	96.80 (2458.6)	100.20 (2545.1)
Shipping Weight	lb (kg)	32 150 (14 583)	32 120 (14 569)

Note: General configuration not to be used for installation. See general dimension drawings for detail.

RATING DEFINITIONS AND CONDITIONS

Standby — Output available with varying load for the duration of the interruption of the normal source power. Fuel stop power in accordance with ISO3046/1, AS2789, DIN6271, and BS5514.

Ratings are based on SAE J1995 standard conditions. These ratings also apply at ISO3046/1, DIN6271, and BS5514 standard conditions.

Fuel rates are based on fuel oil of 35° API [60° F (16° C)] gravity having an LHV of 18 390 Btu/lb (42 780 kJ/kg) when used at 85° F (29° C) and weighing 7.001 lbs/U.S. gal. (838.9 g/liter).

Additional ratings may be available for specific customer requirements. Consult your Caterpillar representative for details.